

SPECIFICATION FOR APPROVAL

Description : Magnetic Transducer

Type : ETG.08,5.004.U.BF

Customer's Model No: _____

Date : 2011. 11. 18

Approved Date	
Customer's Approved Signature	

Compro[®]
ELECTRONIC GMBH

Beim Alten Flugplatz 3
D-49377 Vechta, Germany
Tel.: +49 (0)4441/89112-50
Fax.: +49 (0)4441/89112-55
web: www.compro.de
e-Mail: info@compro.de

Designed By	Checked By	Approved By
朱玉	E. Mpouras	

1. SCOPE

This specification applies Magnetic transducer ETG.08,5.004.U.BF

2. SPECIFICATOIN

Test condition TEMP.=25°C

Item	Unit	Specification
Rated Voltage	V _{o-p}	3.6
Operating Voltage	V _{o-p}	2.5-4.5
*Rated Current (MAX.)	mA	100
*Sound Output at 10cm (Min.)	dB	85
*Rated Frequency	Hz	2700
Coil Resistance	Ω	16±3
Lead Pin Material		SMD
Operating Temperature	°C	-30~+70
Storage Temperature	°C	-40~+85
Housing Material		LCP
Weight	g	0.6
*Value Applying at Rated Voltage.		

3. APPEARANCE DRAWING

Unit:mm Tolerance:±0.2mm

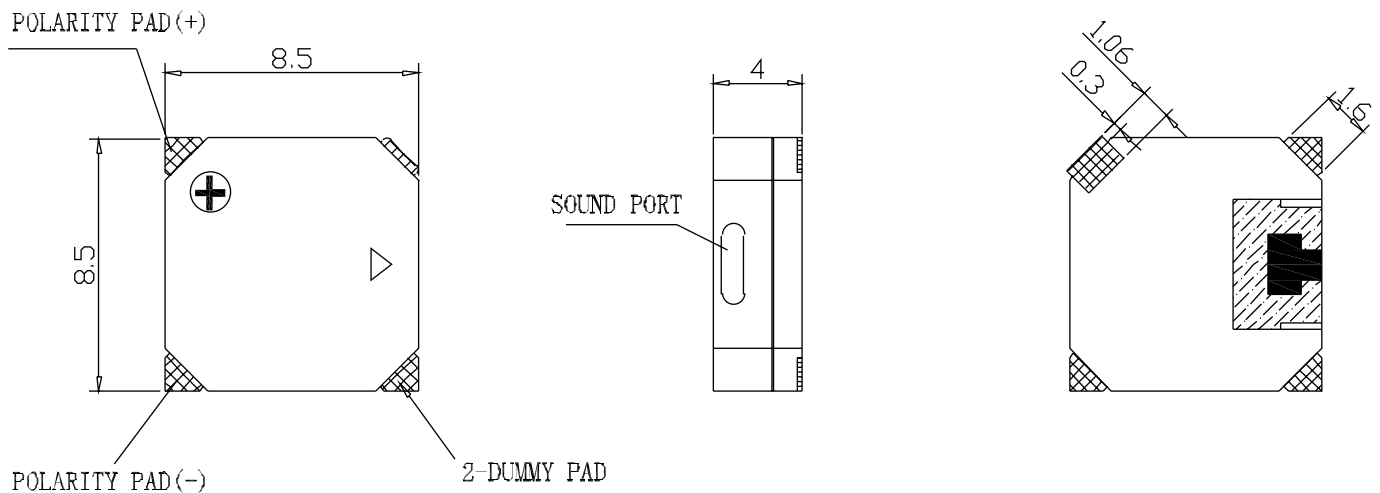

4. MEASURING MENTHOD

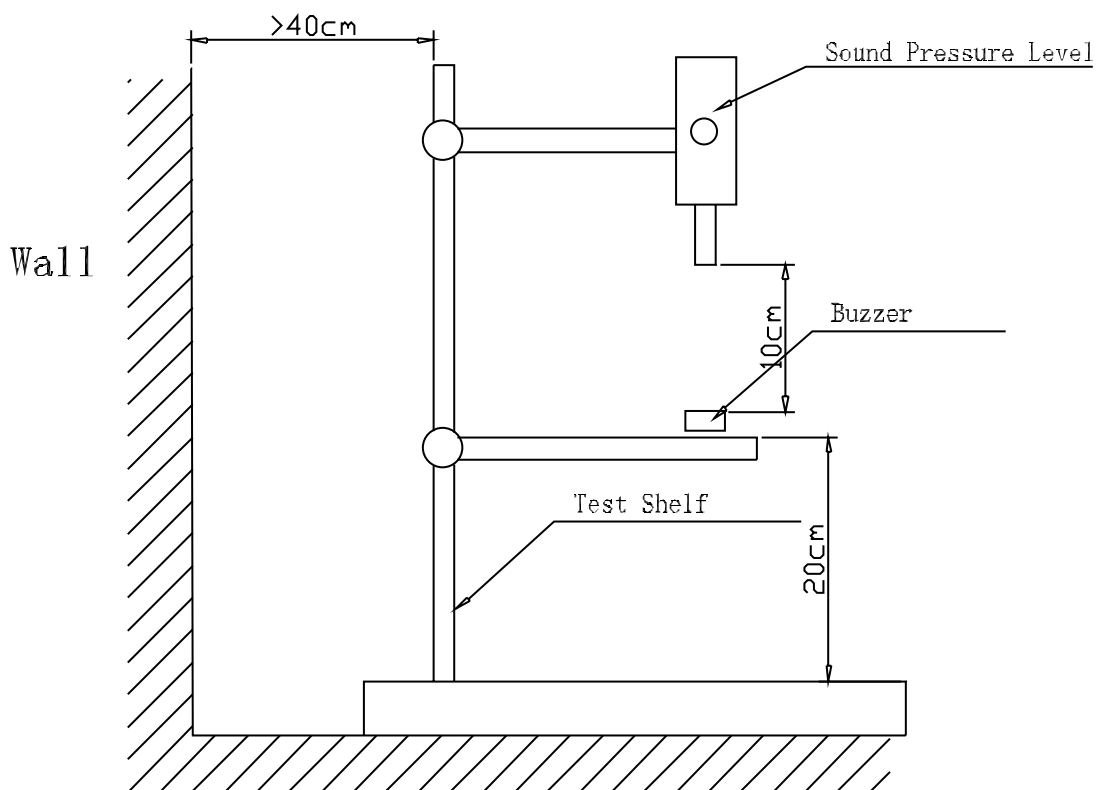
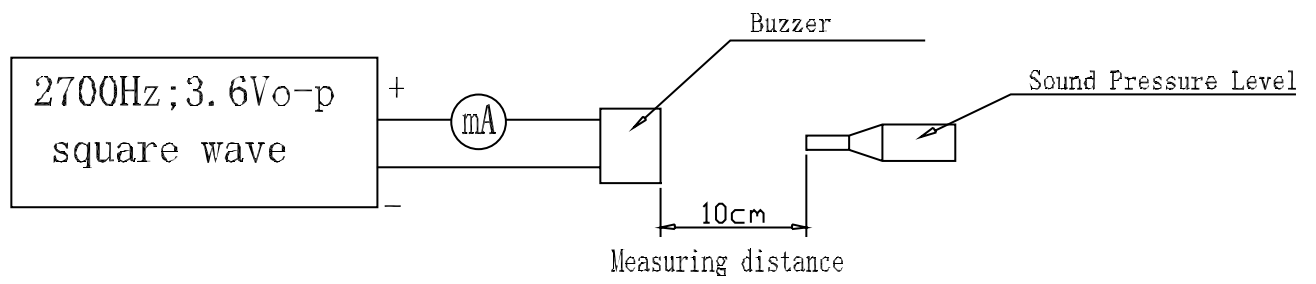

5. RELIABILITY TEST

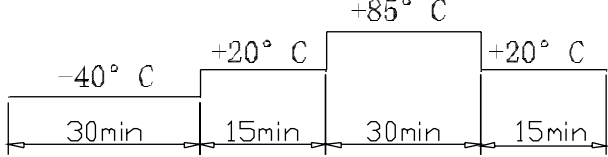
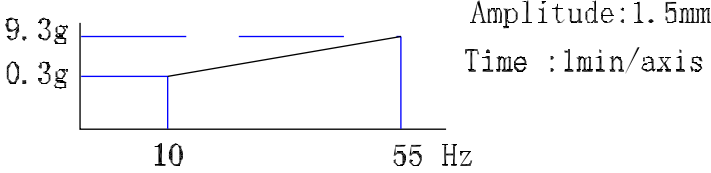
ITEM	TEST CONDITION	STANDARD
Storage in high temp.	Storage in $+85\pm 2^{\circ}\text{C}$ test box for 240 hours, then expose to the room temperature for 2 hours without applying power.	
Storage in low temp.	Storage in $-40\pm 2^{\circ}\text{C}$ test box for 240hours, then expose to the room temperature for 2 hours without applying power.	
Storage in humidity	Storage in $+40\pm 2^{\circ}\text{C}90-95\%RH$ test box for 48 hours, then expose to the room temperature for 2 hours without applying power.	After test The value of frequency/ current/SPL should be meet specifications
Temperature cycle test	 <p>Make this test for 5 cycle without applying power, then expose to the room temperature for 2 hours</p>	
Vibration test	 <p>Make this test for the directions of X, Y, Z for 2 hours each (total 6 hours).</p>	
Drop test	Drop from the height of 100cm to the surface of 100mm thick woodenboard. three directions (X, Y, Z).	
Solderability test	Soldering temp. : $260\pm 5^{\circ}\text{C}$. Heat applying time: $3\pm 0.5\text{sec}$.	90%min. lead terminals shall be wet with solder
Lead Pin Strength Pulling	The force 10 seconds of 9.8N is applied to each lead pin in axial direction	No damage and cutting off

6. PACKING

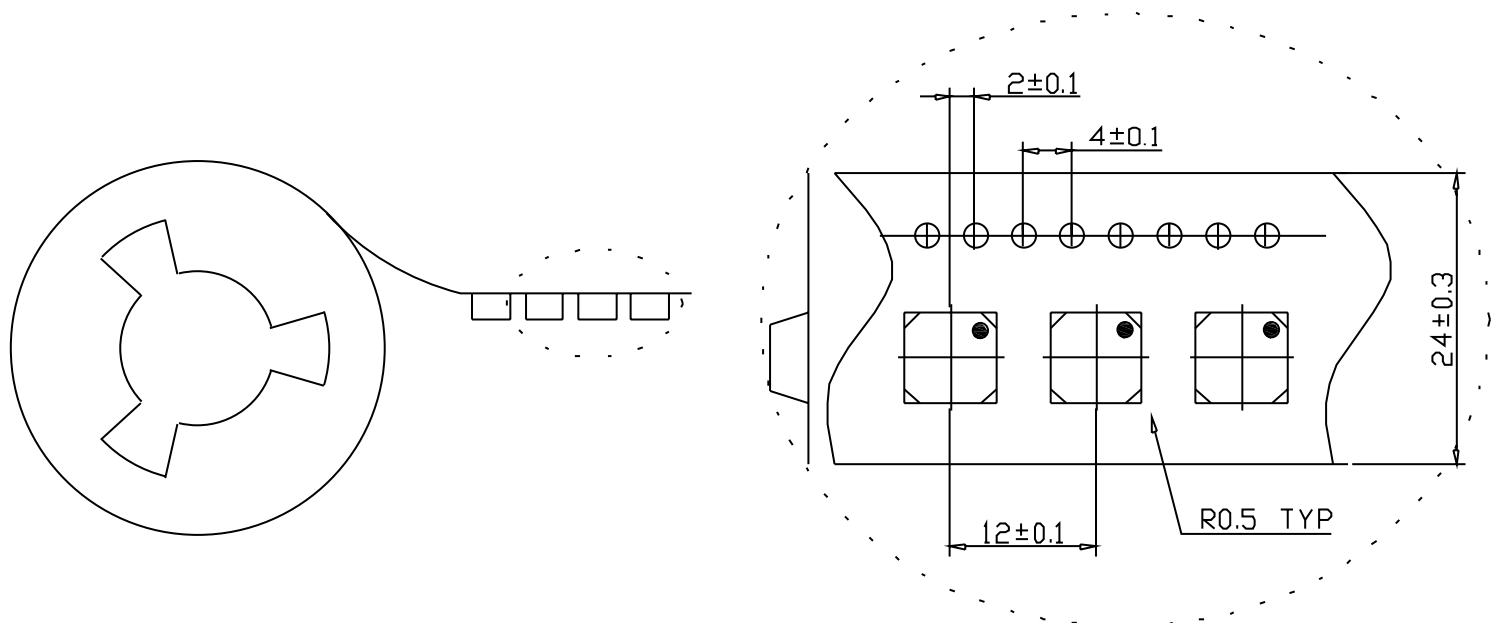

1000PCS

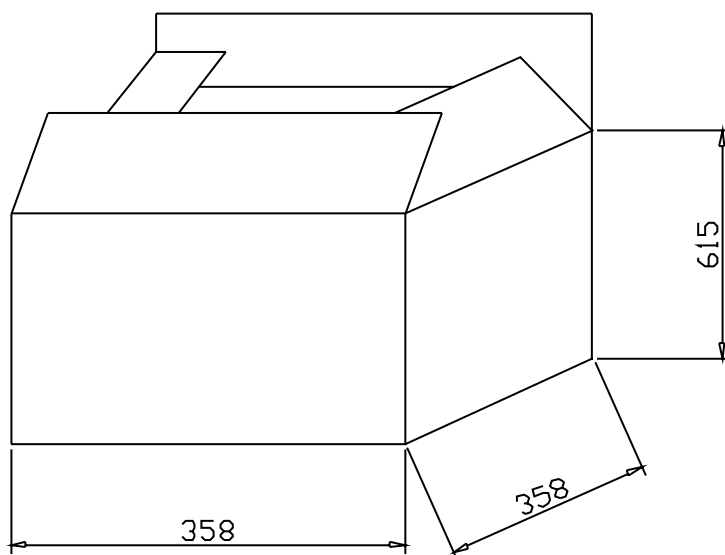

10000PCS/CTN